

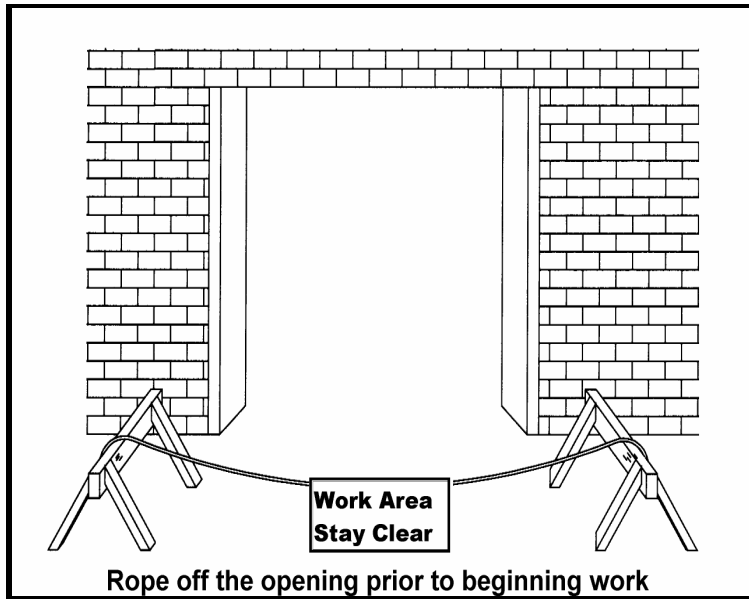

**INSTALLATION & MAINTENANCE  
INSTRUCTIONS FOR  
ROLLING STEEL DOORS  
AND GRILLES**

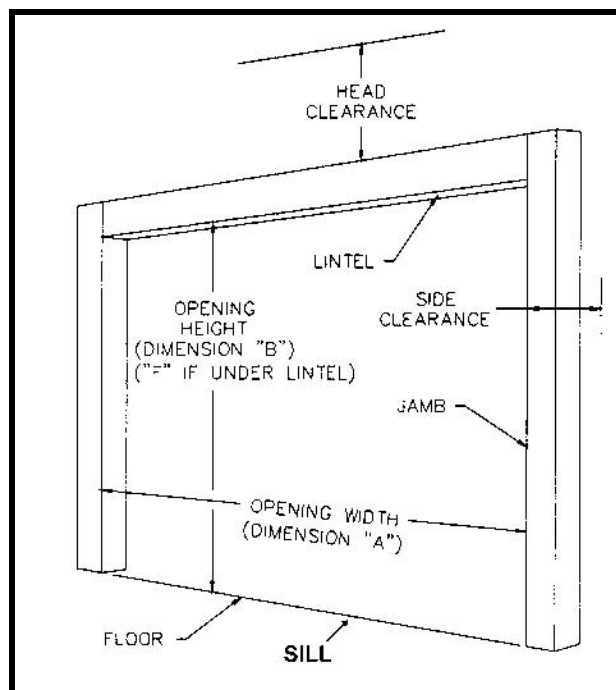

- STEP 1** MAKE SURE ALL PARTS HAVE BEEN RECEIVED. IF PARTS ARE MISSING NOTIFY FACTORY IMMEDIATELY
- STEP 2** READ ALL OF INSTALLATION INSTRUCTIONS BEFORE YOU START.
- STEP 3** MAKE SURE THE OPENING IS THE PROPER SIZE.
- STEP 4** CHECK TO SEE THAT SILL IS LEVEL. If Sill is out of level, mark high Sill level location on low Side Jamb.





**STEP 5 CHECK BOTH LEFT AND RIGHT WALL SURFACES, AND SURFACE AT THE HEAD (ABOVE OPENING) TO ASCERTAIN THAT ALL THREE SURFACES ARE IN LINE AND NO OBJECTS OBSTRUCT THE PROPER INSTALLATION OF :**  
A- WALL ANGLES  
B- SPRING ASSEMBLY  
C- THE TRAVEL OF THE CURTAIN.

**STEP 6 ARE GUIDES YOU RECEIVED SUITABLE FOR THE JAMBS?**

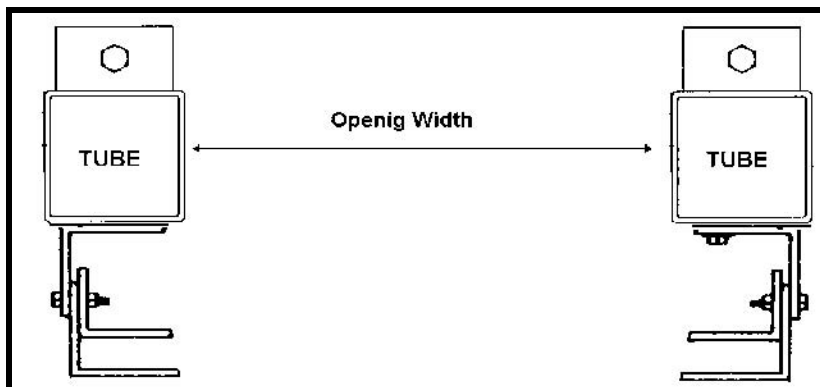
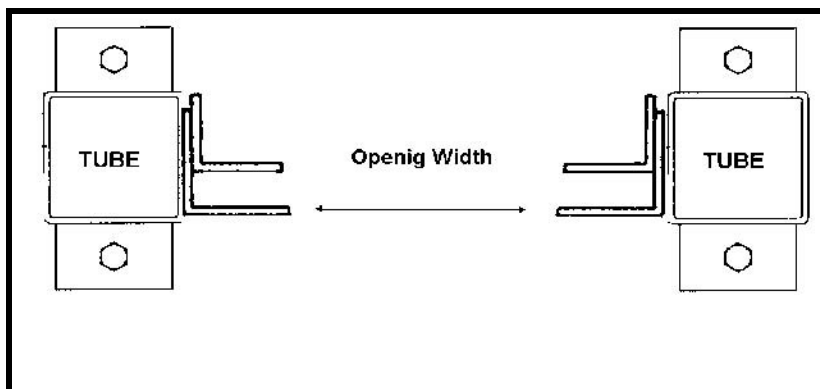
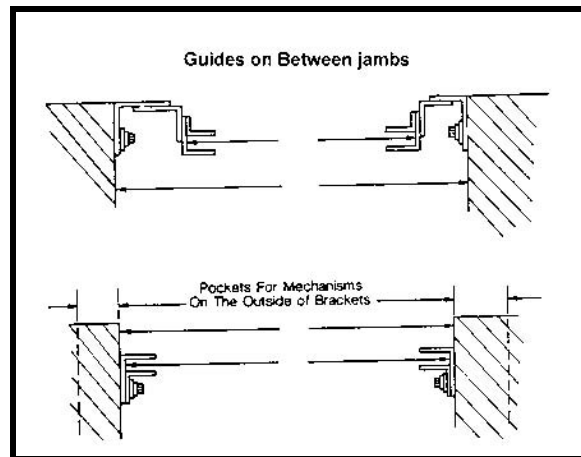
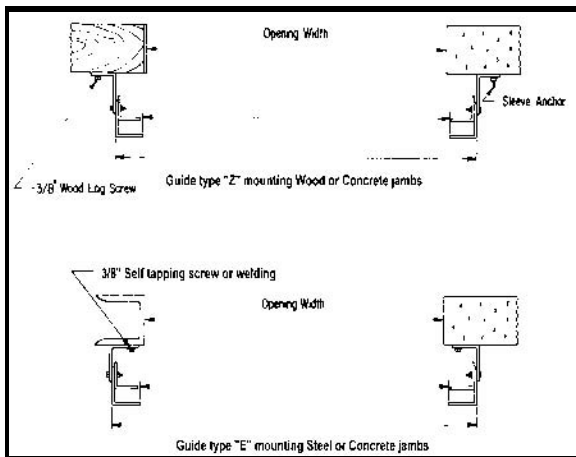



**STEP 7 VERIFY THAT GUIDES CAN BE INSTALLED PLUMB.**

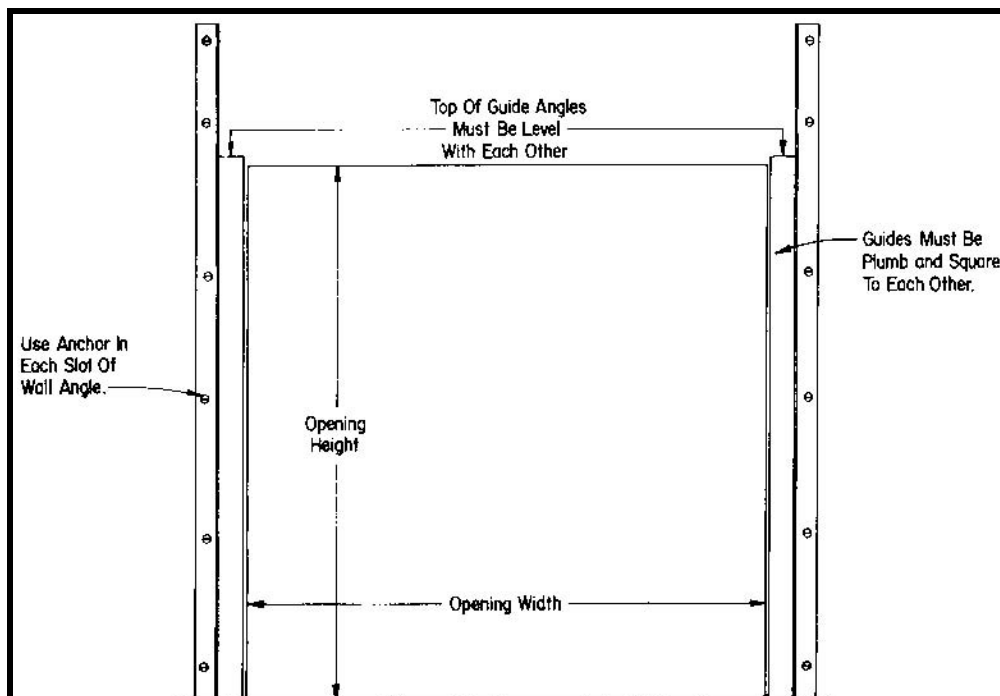

**STEP 8 LOCATING GUIDE ASSEMBLIES.** Locate guide assemblies such that "R" Dimension exists between guides as shown. Bottom of guides **MUST** be on a level line and Guides **MUST** be plumb.

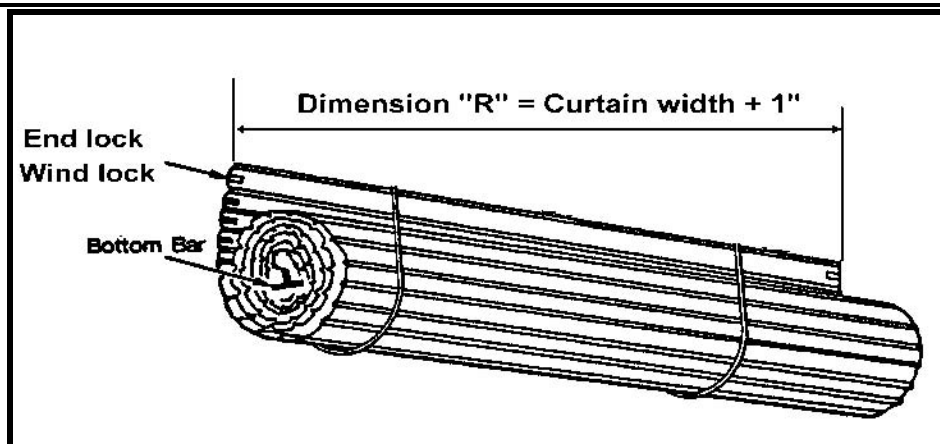
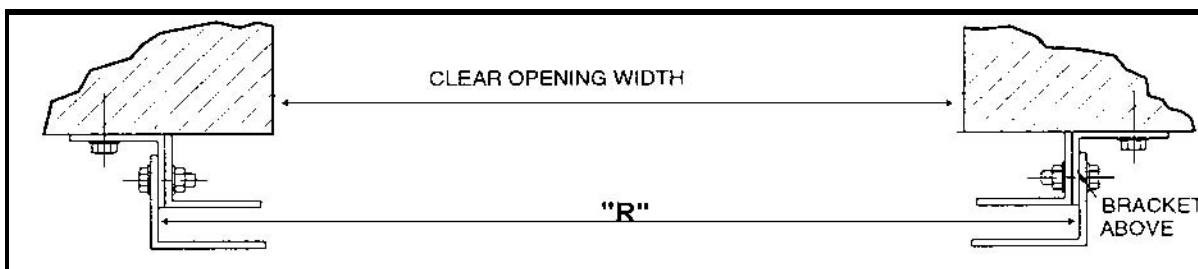



## STEP 9 MASONRY JAMBS

Hold "Z" guide, or wall angle ("E" guide) against wall and drill mounting holes thru the slots. Recheck "R" distance before proceeding. Install wall fasteners.

### SLEEVE ANCHOR

**DRILL HOLE**

**INSTALL ANCHOR**

**TIGHTEN NUT**

### RAWL-BOLT

**DRILL HOLE**

**INSTALL ANCHOR**

**TIGHTEN NUT**

1. Hold angle firmly against wall.
2. Drill hole perpendicular to surface. Hole depth should be equal to full length of expansion anchor.
3. Blow dust out of hole. A clean hole insures highest holding value.
4. Position sleeve anchor nut on end of bolt threads to protect threads when tapping bolt into hole. Install washers on anchor.  
Remove tag from Rawl-Bolt.
5. Tap anchor into hole until washers and angle rest against surface.
6. Recommend using hand wrench ONLY. Tighten anchor 2 to 4 turns past the hand tight position. DO NOT EXCEED installation torque shown below.

**Max. Torque (Ft-pounds)**

Anchor Type	Anchor Diameter			
	3/8	1/2	5/8	3/4
Sleeve Anchor	16	28	60	90
Rawl-Bolt	35	60	100	120

## STEP 10 STEEL JAMBS. (Screw Attachment Option)

Hold "E" guide against steel jamb and mark the spot to be drilled, or hold wall angle against steel jamb and drill holes thru the slots. Recheck "R" distance before proceeding. Install jamb fasteners.

## STEP 11 STEEL JAMBS. (Weld Attachment Option)

Hold "E" guide against steel jamb and tack weld wall angle in place. Recheck "R" distance before proceeding. Weld using welding electrode. All welds must be good quality 3/16" fillet welds. Weld the angle to the steel jamb along the top of the angle.

**IMPORTANT:** When steel jamb does not extend above the opening, use three thru-bolts to fasten each wall angle above the opening.



**STEP 12 IDENTIFY HEADPLATE BRACKET**

Right Hand Drive shown; Left Hand Drive is opposite.

**STEP 13 IDENTIFY BARREL ASSEMBLY DRIVE END**

Right Hand Drive shown; Left Hand Drive opposite.

TENSION END BRACKET	DRIVE END BRACKET
<p>Welded Tension Stop</p>	<p>Identified by Bearing</p>
<p>Refer to specifications. For a right hand door, drive end bracket locates on right guide assembly. On left hand door, drive end bracket locates on left guide assembly.</p>	

<p>Bearing</p> <p>Movable Shaft with pinhole</p> <p><b>Tension End</b></p>	<p>Weld</p> <p>Rigid Shaft with keyway</p> <p><b>Drive End</b></p>
--	--

**Use a Right Hand Drive Bracket with a Right Hand Drive Barrel to prevent Torsion Spring failure in barrel, which can allow Curtain to free fall causing DEATH OR SERIOUS INJURY. Left Hand Drive Bracket and Left Hand Drive Barrels MUST match also.**

**STEP 14 ORIENT BARREL AND HEADPLATE BRACKETS**

Slide Drive End of Barrel Assembly through Drive Bracket Bearing and Tension End through Tension Bracket. Secure Tension Wheel to Shaft using Pin or Key.

Position Barrel in Front of Opening as Shown. Be Sure Drive End of Barrel is Placed on Right Side of Opening for Right Hand Operation and Left Side for Left Hand Operation.

TENSION END SHAFT

PIN

TENSION WHEEL





### STEP 15 LIFT BRACKETS AND BARREL AND BOLT TO GUIDE WALL ANGLES

With Forklift or Some Type of Lifting Device Raise Barrel and Brackets to Top of Guides. Use Carriage Bolts to fasten Headplate Brackets to inside of Guide Wall Angles. Bolt heads are to be on inside of Brackets. Brackets are to be square to Wall and parallel. Center Barrel between brackets. Use a level to make sure Barrel Assembly is level.

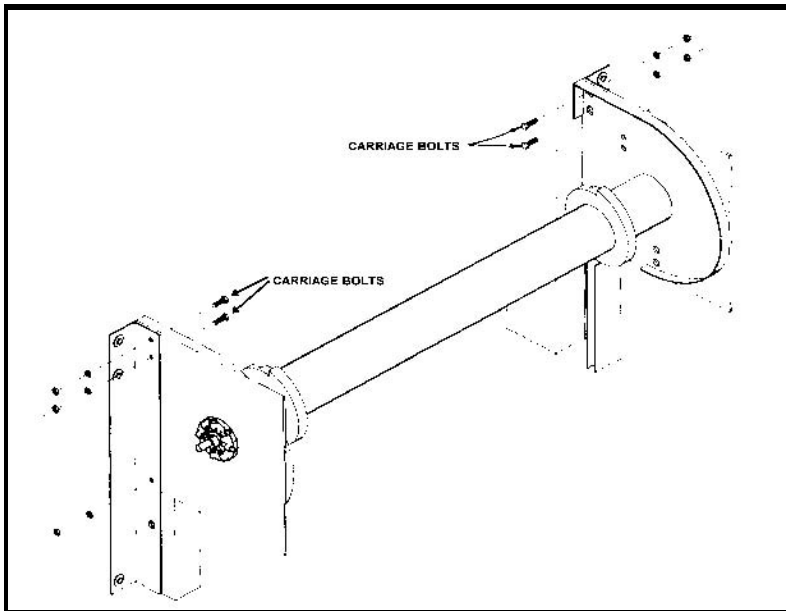

USE PROPER LIFTING  
EQUIPMENT  
AND CORRECT LIFTING  
PROCEDURE TO AVOID  
INJURY.

### STEP 16 DRIVE ASSEMBLY CHAIN HOIST ASSEMBLY.

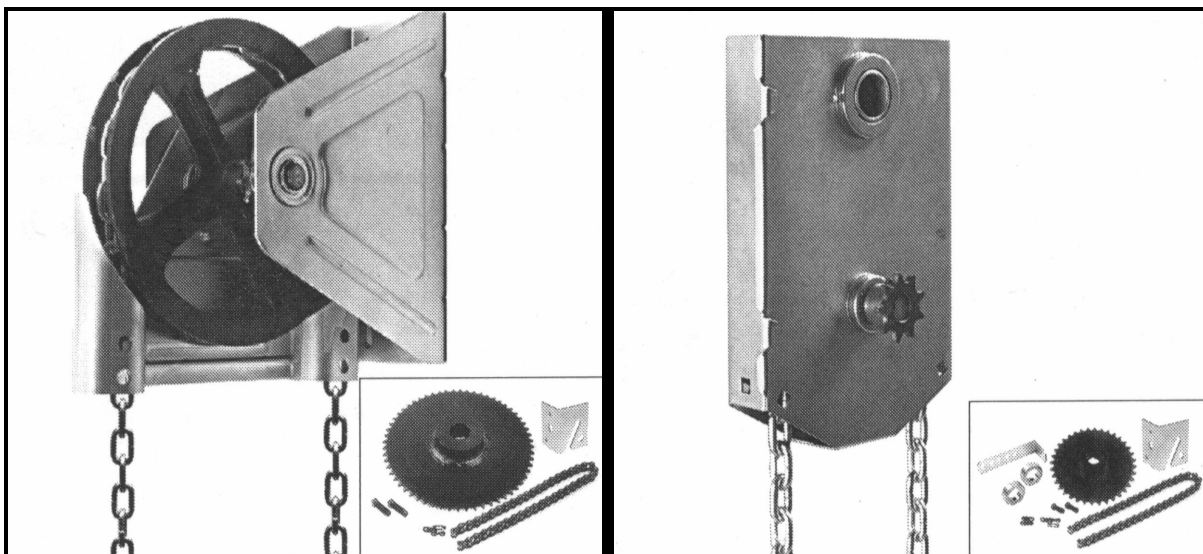

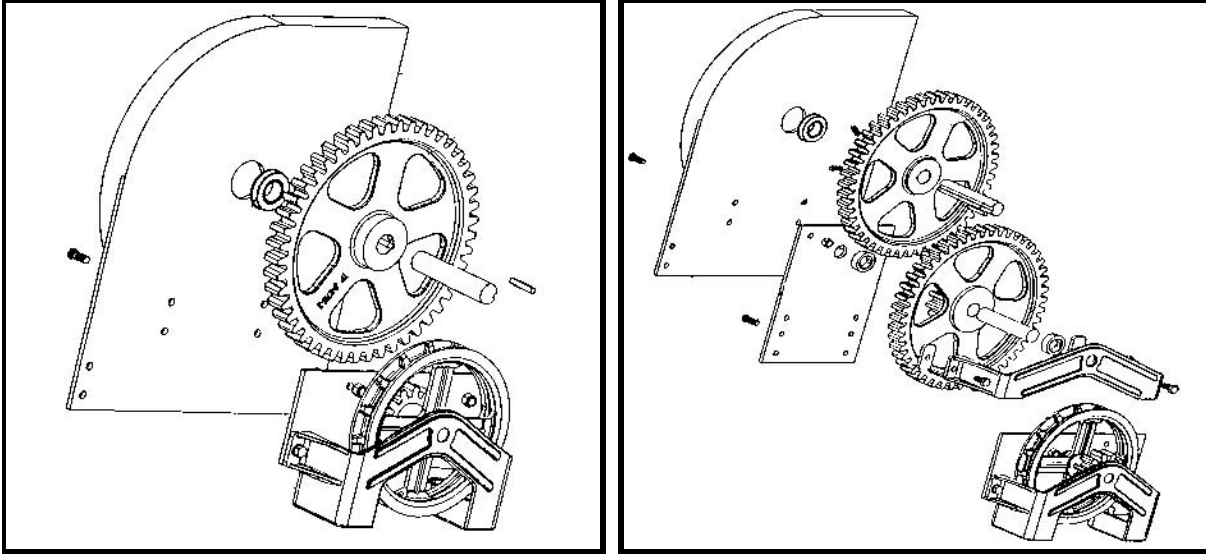

**CRANK ASSEMBLY.**

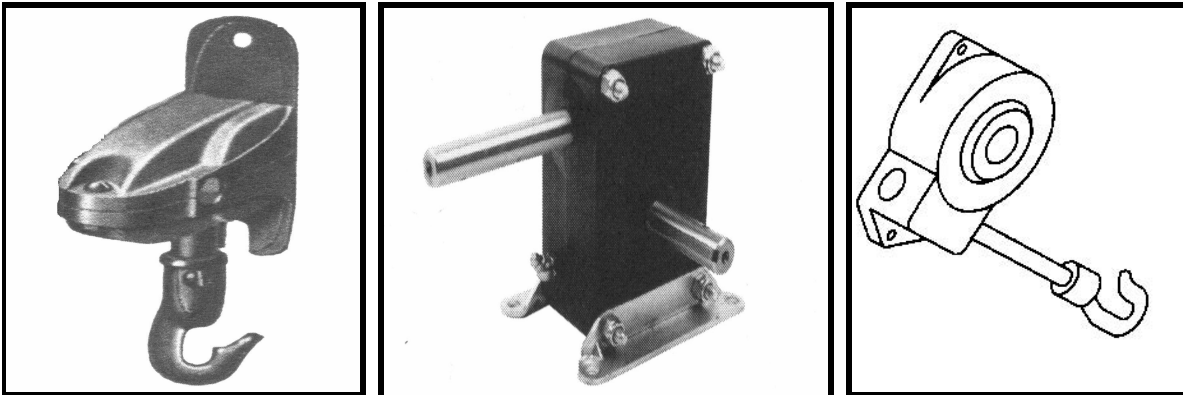

**MOTOR ASSEMBLY.**

**TO BRACKET PLATE**

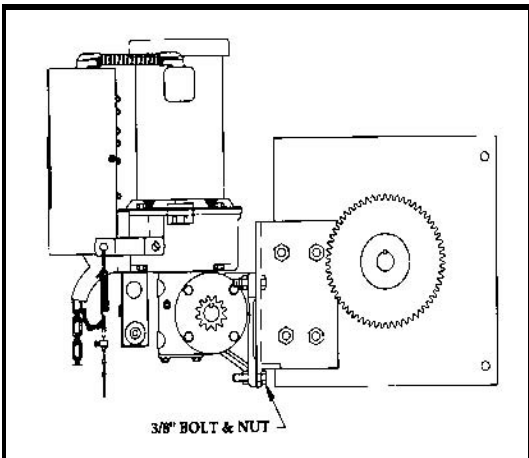

**TO WALL**

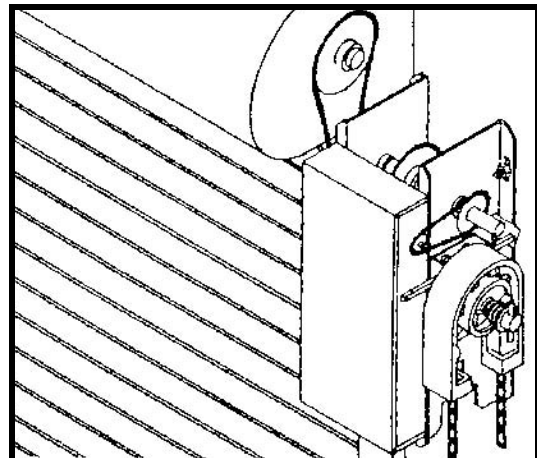





### THRU WALL CHAIN

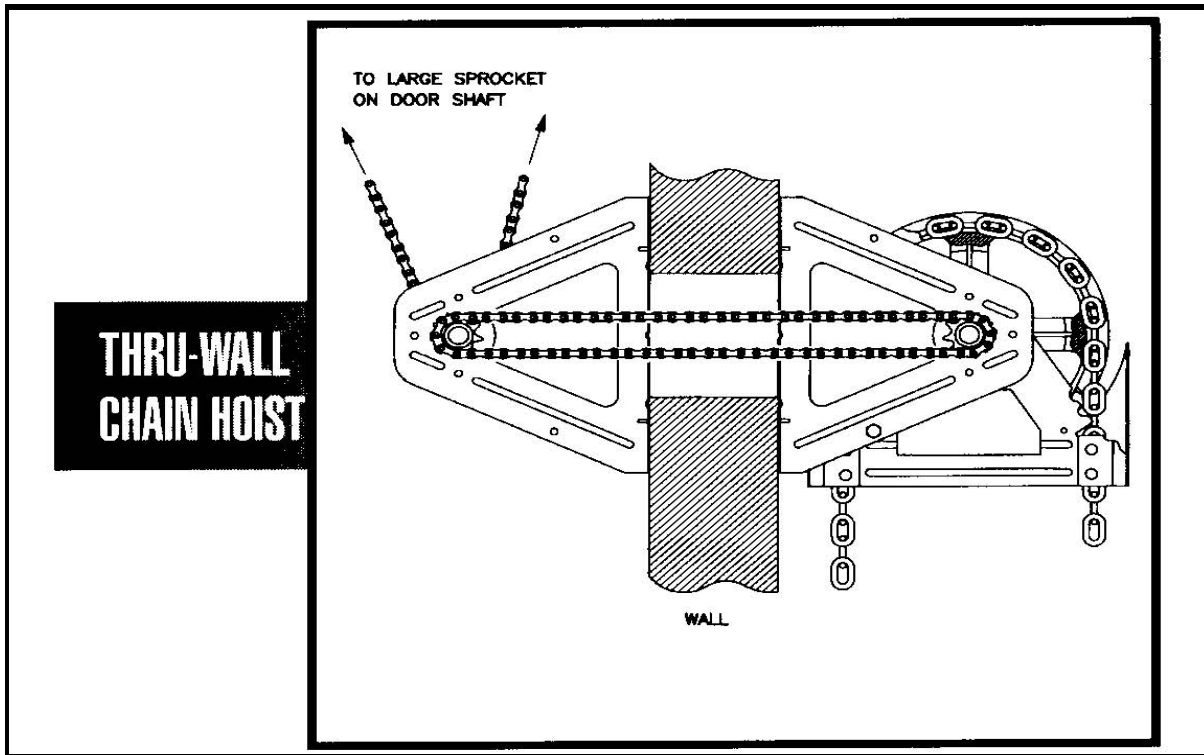

### THRU WALL CRANK

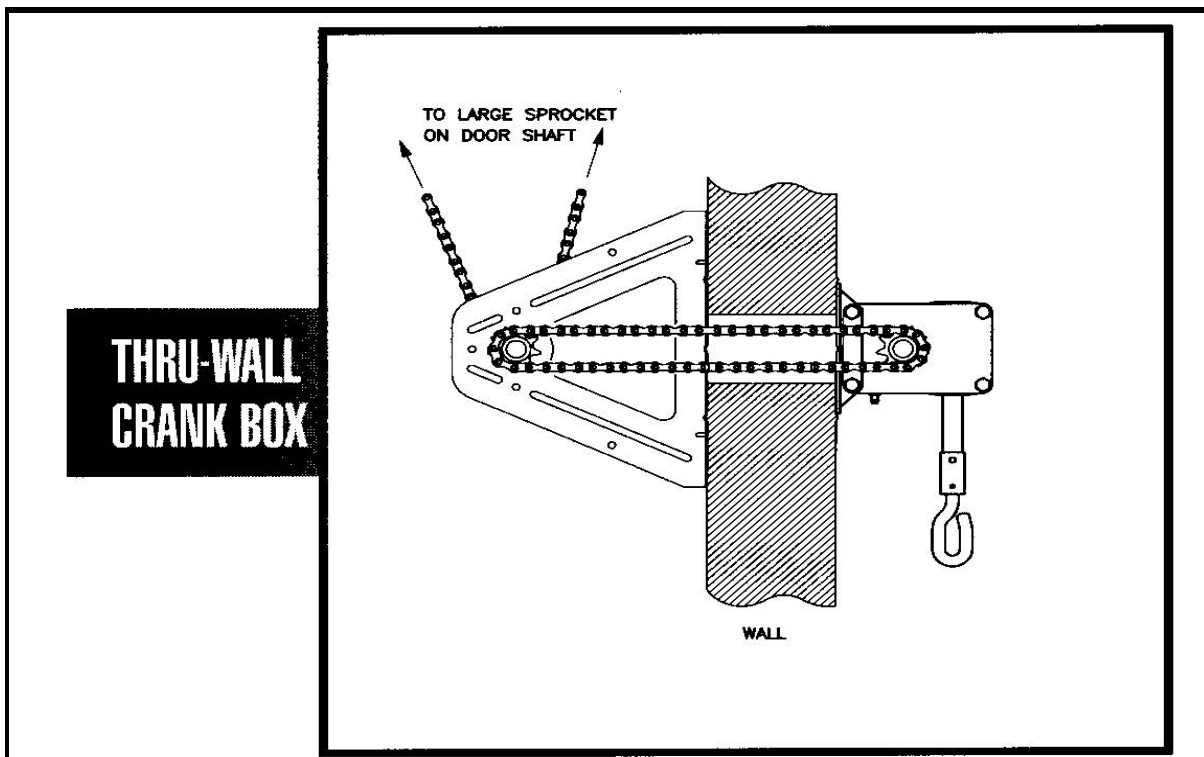



## STEP 17 INSTALLATION OF CURTAIN (SLING METHOD)

Hang the Curtain on two or more Slings or Heavy Ropes capable of suspending the curtain weight. Ropes/Slings **MUST** be able to suspend the Curtain weight. Fasten the Top Slat to the Slings or Ropes with wire. Rotate the Barrel to bring the Top Slat in place. Center the Curtain between the Headplate Brackets.

If the Barrel Assembly has Rings, pull the curtain up and hold the Top Slat against the Rings making sure Curtain is evenly centered on Barrel. Attach Top Slat to Rings with 3/8" Screws and Washers provided. **DO NOT** strip Screw Threads.

If Barrel Assembly has Studs, the Top Slat will have slots to attach to Barrel. Hook Curtain over Studs and fasten with 5/16" Round Head Screws and Washers provided.

If Slat Segments are provided at the Top of the Curtain, fasten them to Rings or Studs after Curtain is centered. Then crimp the Slat Curl adjacent to each Slat Segment.

**The Sling Method causes less damage than rolling the Curtain onto the Counterbalance while it is on the floor.**

## COMPLETE CURTAIN INSTALLATION

Coil Curtain completely onto Barrel.

If Guides are Flared, then install the Middle Angle and Outside Guide Angles.

Place locking pliers on the Guides as shown.

Lower Curtain into Guides.

Lock the Drive to prevent the Curtain from falling.

If the Guides are not flared, install Curtain Stop Bellmouth on Guides. A Stud is attached to the Guides to hold the Bellmouth. Be certain the back of the Bellmouth is flush against Headplate.

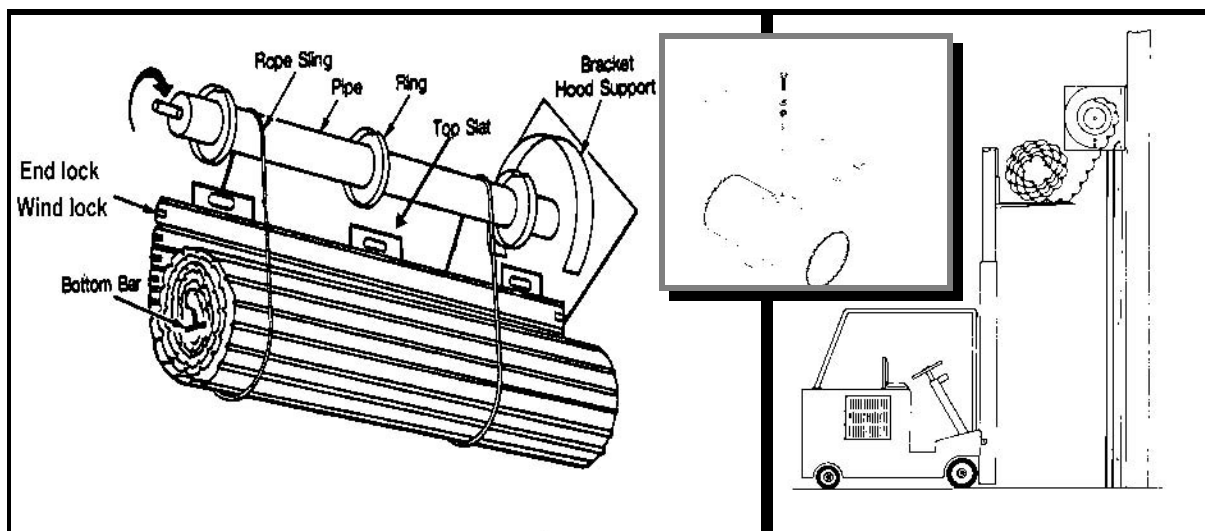



### STEP 18 APPLYING SPRING TENSION.

Wind Tension Wheel in the direction shown in figure.

Warning this step can be extremely hazardous. Read and understand this section fully before proceeding.

Applying spring tension requires two workers for safety. you will need (2) 1/2" to 5/8" steel rods 2 to 3 feet long (not provided) to apply tension to the springs. Slide one of the round bars into any of the holes of the tension wheel. Wind in the direction the pipe would rotate when the door is going up (i.e. adjuster at left, clockwise, adjuster at right, counter clockwise) slide the second round bar in the hole above hold and remove the lower bar. Repeat the procedure until the curtain starts to coil around the spring assembly and stop when the bottom bar becomes visible. Line up the tension wheel stop with the angle stop and slide the stop round bar provided through stop angle and into the hole in the tension wheel. Remove the adjusting bar.

**TENSION WHEEL CAN SPIN RAPIDLY IF RELEASED.**

**WHEEL IS UNDER EXTREME TENSION.**

**USE OF IMPROPER TOOLS CAN CAUSE SERIOUS INJURY.**

**DOOR MUST BE FULLY OPEN AND CURTAIN WRAPPED ON THE BARREL.**

**WINDING BARS MUST BE 1/2" TO 5/8" DIAMETER STEEL RODS, 2 TO 3 FEET LONG.**

**DO NOT USE PIPE, CONDUIT, SCREWDRIVERS, ETC., AS WINDING BARS.**

**DO NOT ALLOW UNCONTROLLED FREE FALL CLOSING OF DOOR. INSTRUCT CUSTOMERS TO USE BOTH HANDS TO CONTROL BOTH HAND CHAINS DURING THE CLOSING OPERATION.**

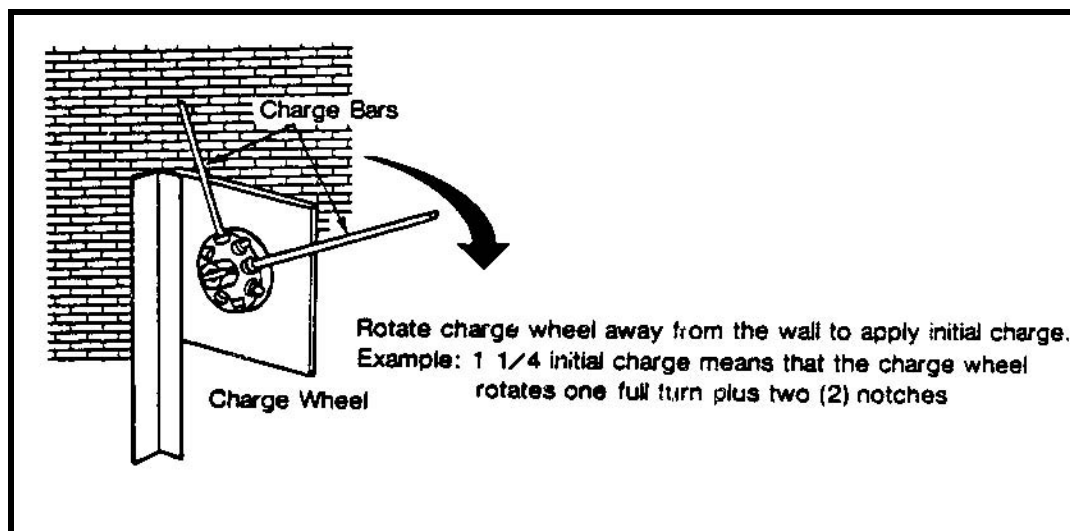



### STEP 19 INSTALLATION OF CURTAIN

Place a pair of vise grips about 4" down from top on both guide. Insert the ends of the bottom bar into the guide channels, and lower the curtain so that the bottom bar is approximately 4 inches below stop height until the bottom bar rest against the vise grips. Install the two stop bell mouth at front of the guides with the bolts and nuts provided.

### STEP 20 ADJUST TENSION WITH DOOR IN FULLY OPEN POSITION.

Adjust tension one notch at a time to increase or decrease torque as required.

### STEP 21 FINAL CHECKOUT. (TO BE COMPLETED BEFORE INSTALLING HOOD)

1. The Guides may be lubricated with a Paste Wax or Silicone Spray.
2. Verify thru entire travel of the door that the Endlocks or Windlocks on the end of the Curtain are not rubbing the Headplate Brackets. Operate door several times to check for problems.
3. Check that Bottom Bar is level in full down and full up position and that Curtain is not binding against back of Guide.
4. If Curtain is level at bottom and not level at top, put Shims between Curtain and Counterbalance on the low side.

### STEP 22 HOOD INSTALLATION

If Hood Supports are provided, snap a line across top of Headplate Brackets on the Wall. Measure length of Hood Sections and locate Hood Support so that Hood Splice will fall on center of Support.

Attach Hood to Hood Bands on Bracket Plates (and to Supports if provided) by drilling a 7/32" hole through Hood and Band. Then secure with 1/4" dia. x 3/8" long Self-tapping Screws (five per Bracket and five per Support).

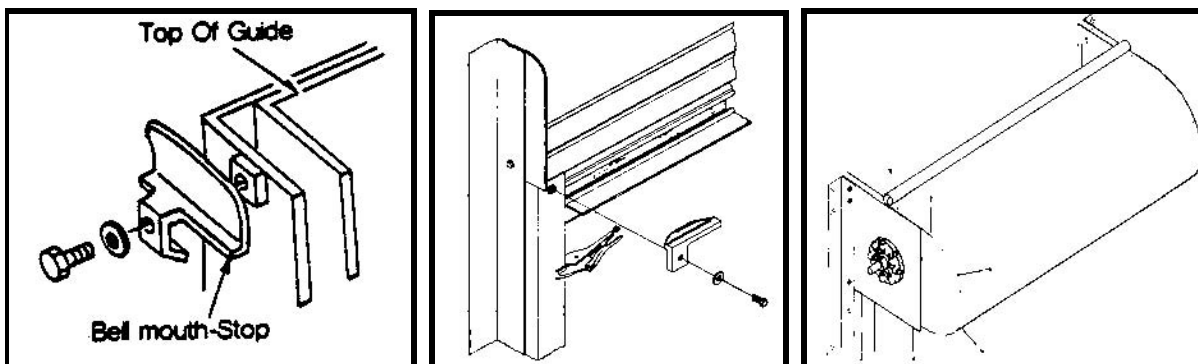



## INSTALLATION INSTRUCTIONS FOR BAND SPRING DOORS AND GRILLES

- STEP 1** Install vertical guide rails with attached bracket plates as per spec dimensions.
- STEP 2** Put pipe into “V” cups, in housing brackets plates.
- STEP 3** Spin pipe until you see fold of spring around cross member of spring basket, fold should be downwards, if reversed, take off and turn.
- STEP 4** Spin pipe again, so pin at side of basket is facing downward. Bolt pipes to “V” cups.
- STEP 5** Slide “S” hooks onto lead slats (as many as spring basket).
- STEP 6** Raise curtain an attached "S" hooks to cross member of spring basket towards top of basket.
- STEP 7** Pull down on curtain lightly in order to release holding pin at side of basket.  
If pin does not release, pull out manually. (Make sure “S” book is secure around cross member of basket).
- STEP 8** Let curtain wrap around basket then insert into guides.
- STEP 9** Check tension, if more is needed, turn each spring box one complete revolution clockwise. If less is needed, do the opposite. If one is too much and only half is needed, then you must hold spring box with level or screw driver to stop spring from unwinding and change the “S” hook to another cross member of the basket either up or down. Whatever adjustment is made to one basket, do to all baskets. Do not put “S” hook on cross members that have the spring wrapped around it.
- STEP 10** Put stops on guides.
- STEP 11** It's a good idea if housing brackets are greased before hood is installed.



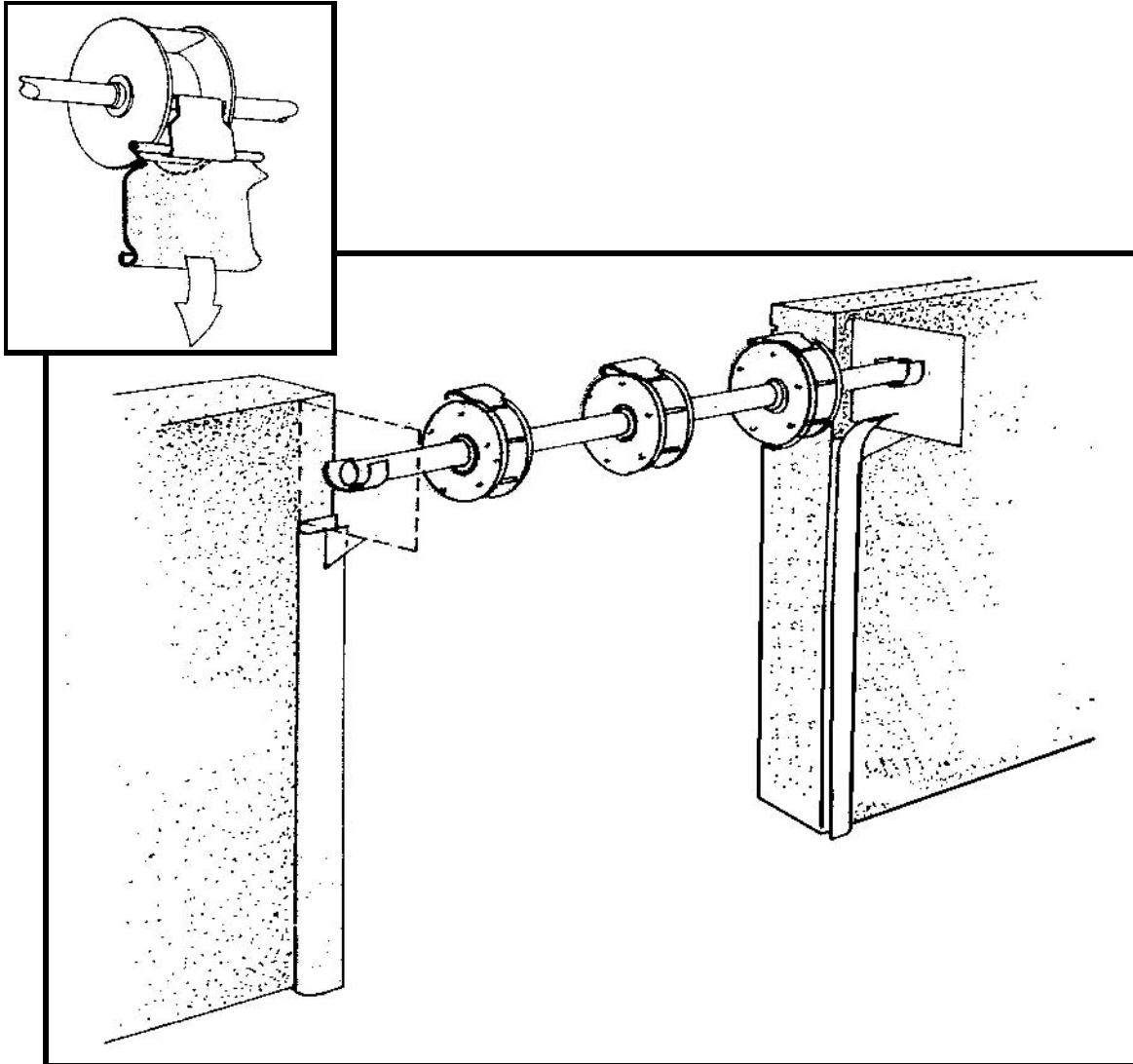

**TAKE EXTREME CAUTION WITH PIN ATTACH TO SPRING BOX. DO NOT REMOVE PIN UNTILL CURTAIN IS ENGAGE TO SPRING BOX.**

**“WARNING COIL IS AT FULL CHARGE RELEASING PINS CAN CAUSE BODILY INJURY OR DEATH”**



## PUSH-UP OPERATION

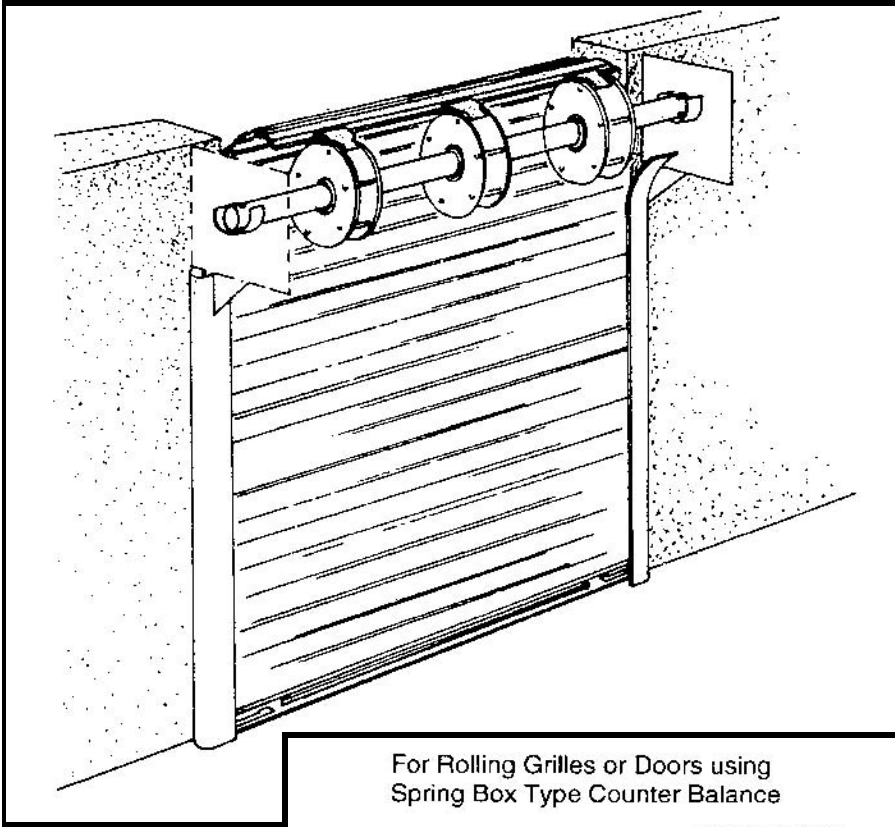

## MOTOR OPERATION

